

## Drying Conditions for Rice and Tomato

H.S.Sultane

Mechanical Department RSCOE, Buldhana Haridassultane200@gmail.com

### Abstract

In order to predict or control the behavior of a drying system, drying conditions were investigated by computer simulation and fieldwork activities. Test runs with dryers were carried out over a long period of time at many locations across the country.

Drying conditions for rice and tomato are proposed.

**Key words:** Drying Conditions, Rice, and Tomato.

### I. INTRODUCTION

Three participants are involved in the realization of food drying process: (1) drying medium, (2) Dried product, (3) dryer.

The combination of medium state, product state and dryer construction, which provides quality dried product, is known as “drying conditions” for the actual product. Drying conditions are important for drying theory and practice, [1], [2].

Generally, drying medium for cereals, fruits and vegetables is the atmospheric air. The mechanism of drying that occurs in those dryers is the process of simultaneous heat and mass transfer. The intensity of the transport phenomena is influenced by medium characteristics: air temperature, air relative humidity and air velocity. The state of the air in the atmosphere can be predicted with the help of Climatic curves for specific location. Air velocity or airflow rate is estimated by experience or by laboratory measurements. The state of the dried product is determined by its moisture content, temperature and thickness.

Moisture content is expressed as initial moisture content (at the entrance of the drying room) and as final moisture content (at the exit of the drying room).

The thickness of dried cereal is different for shallow-layer drying and deep-bed drying. In the shallow-layer drying columns, typically 300 mm wide, or layer, from 600 to 1500 mm thick, are used. In deep - bed drying a perforated floor and duct systems placed on the floor are the most common means. The maximum depth of rice to be dried is limited by the cost of the fan, the air distribution system and the power required.

The thickness of dried fruits and vegetables is usually equal to the single product dimension or smaller when the product is cut into pieces.

There are many different food dryer constructions on the market today. Basically, they

belong in four categories: the fixed bed dryer, the cross flow dryer, the concurrent flow dryer and the counter flow dryer. The industrial type dryers were used for estimation of rice drying conditions. Small or farm dryers were used for evaluation of tomato drying conditions.

### II. DRYING CONDITIONS FOR RICE

The rice varieties in Macedonia are mostly from Italian origin. The sort “Monticelli” dominates. At cultivated area of maximum 10000 ha, 50000 t paddy crops is realized. Before the storage paddy is dried in single-stage dryers of industrial size. Functional draft of one of the test dryers is shown in Figure1. It is composed of ventilator, heater, air ducts and drying room. The grain stream flows by gravity into the drying room with a capacity of twenty tones per eight hours.

An axial ventilator provides 42000 m<sup>3</sup>/h air for the grain- conditioning system. Tube-fin heat exchanger is installed for air drying by steam. In this type of dryer, rice flows continuously over alternating rows of heated air supply and air exhaust ducts. Therefore the grain is mixed and alternately exposed to relatively hot drying air and air cooled by previous contact with the grain, promoting moisture uniformity and equal exposure of the product to the drying air.

Estimation of the quantity of air required to remove the moisture from the dried rice is based on psychometrics, [3], [4], [5]. The thermodynamic properties of moist air are graphically presented in psychrometric chart. The process is single-stage adiabatic drying. The first step in preparation of the outdoor air for the role of drying medium is heating. The maximum ability of moist air to absorb moisture from the dried rice corresponds to the difference between its saturation moisture at wet-bulb temperature and its moisture content at dew point. The second step of the moist air behavior in the

dryer is its humidification. The process of humidification of moist air means drying for the rice. The change of air state is adiabatic saturation, in practice realized until relative humidity of about 80 to 90 % is reached. The drying rate is a function of the entering conditions of drying air and initial moisture content of dried rice.

Thermodynamic analysis of rice drying process uses three kinds of experimentally obtained curves: climatic curves, equilibrium moisture content curves and drying rate curves.

Until today, in our country, climatic curves are published only for Skopje region, [6]. Equilibrium moisture content curve and drying rate curve, for rice variety Monticelli, also exists, [7], [8].

Data obtained from those three curves was used in the mathematical modeling and computer simulation of rice drying process.

In the attempt to establish the drying conditions for rice, the investigation programme of rice dryer simulation and fieldwork activities were realized.

Rice drying simulation based on Bakker-Arkema's analysis was adapted and applied on local rice varieties [9].

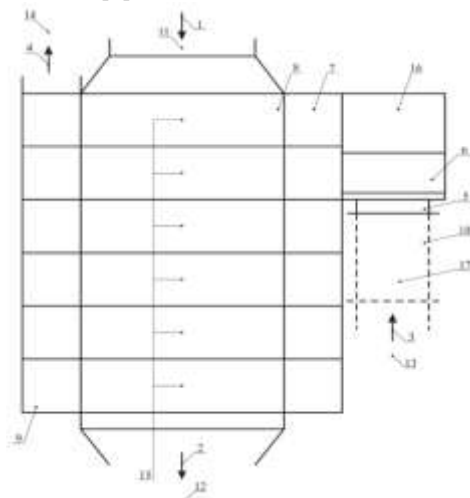

Figure 1: Industrial rack-type continuous-flow rice dryer

Fig.1 shows the general flow of PSO optimization technique in which first we have to generate the initial population for searching of best element. After solving the initial population equations we will get best search points in the population at step 2. And we have to replace the search space elements with optimized elements which will modify the search speed at step 3. if our optimization iteration

reaches the maximum number to get best feasible solution then only we will get optimized results otherwise we have to go to step 2 again to evaluate searching point of each agent. After knowing the mathematical equations for milling machining parameters we can optimize different input parameters such as Process Kinematics, Cutting Fluid, Depth of Cut, Feed Rate, and Step over, Tool Angle, Cutting Speed. Etc. and output parameters can be Material removal rate, Tool life, Productivity, Machining time, cycle time reduction, Machining cost etc.

Dryer elements: 1 - Grain inlet, 2 - Grain outlet, 3 - Air inlet, 4 - Air outlet, 5 - Ventilator, 6 - Heater, 7 - Air duct, 8 - Drying room, 9 - Air duct, 10 - Measuring duct, Measuring points: 1 - Initial grain moisture content, 12 - Final grain moisture content, 13 - Air inlet conditions, 14 - Air outlet conditions, 15 - Grain inside moisture content, 16 - Heated air conditions, 17 - Airflow.

To numerically solve the rice drying simulation model the initial and boundary conditions ought to be correctly and completely estimated for the actual rice variety and dryer. For example, twenty-one parameters were necessary for the rice dryer simulation: specific product surface area, heat capacity of dry air, heat capacity of dry product, heat capacity of water vapor, heat capacity of liquid water, bulk density of grain, heat of evaporation for water in grain, initial grain moisture content, initial grain temperature, initial air temperature, initial air moisture content, airflow rate, layer thickness, number of nodes between outputs, number of nodes, total time, time between outputs, final grain moisture content, grain flow rate, dryer length and dryer width.

The relevant relationships, such as: (1) the change of average moisture content of rice with air temperature, (2) the change of average moisture content of rice with airflow rate, (3) the change of average moisture content of rice with initial moisture content of rice, (4) the change of rice temperature with grain layer depth, were obtained from the computer simulation output.

In the next step, the predicted variables changes were controlled on test dryer. Two groups of measurements were realized: (1) air (flow, moisture, and temperature), (2) grain (flow, moisture, temperature).

Table 1: Drying condition for rice

| Parameter                         |   |            | Dried product:<br>Rice |
|-----------------------------------|---|------------|------------------------|
| <b>Medium</b>                     |   |            |                        |
| <b>Air state (In atmosphere)</b>  |   |            |                        |
| Dry bulb temperature              | $t_a$   | °C         | 10 - 25                |
| Wet bulb temperature              | $t_{wa}$  | °C         | 8 - 17                 |
| Relative humidity                 | $\phi_a$  | %          | 45 - 73                |
| <b>Air state (In drying room)</b> |   |            |                        |
| Dry bulb temperature              | $t_r$   | °C         | 30 - 42                |
| Wet bulb temperature              | $t_{wr}$  | °C         | 19 - 21                |
| Relative humidity                 | $\phi_r$  | %          | 14 - 35                |
| Airflow                           | $m$   | $m^3/m^2s$ | 0,01 - 0,04            |
| Specific enthalpy rise            | $\Delta h$  | kJ/kg      | 21 - 34                |
| Humidity ratio rise               | $\Delta W$  | kg/kg      | 0,0033 - 0,0048        |
| <b>Product</b>                    |   |            |                        |
| Initial moisture content          | $X_{wb}^o$  | %          | 16 - 25                |
| Final moisture content            | $X_{wb}^*$  | %          | 10 - 14                |
| Initial temperature               | $t_p^o$   | °C         | 12 - 22                |
| Final temperature                 | $t_p^*$   | °C         | 36 - 38                |
| Thickness                         | $h$   | mm         | 100 - 250              |
| <b>Dryer</b>                      | <b>Industrial rack-type continuous flow dryer</b> |            |                        |

The Pitot tube in conjunction with a precise manometer was applied for airflow rate measurement at measuring point 17. Air conditions were determined with psychrometers at measuring points 13 and 14. The used digital thermometers for measuring points 13, 14 and 16 had accuracy 0,2 % of the measured value, a thermocouple NiCr/Ni sensor, reaction time of 0,3 seconds and sensor diameter of 1,5 mm. Alternatively, the relative humidity was measured with the use of digital hygrometers. They had accuracy of 2 % of the measured value, dielectric sensor and sampling rate of 2 measurements per second. The grain flow rate was adjusted by controlling the speed of the screw conveyor. The initial, internal and final moisture content of grain was inspected by taking representative grain sample in the measuring points 11, 12 and 15. The desirable final grain moisture content was reached at three levels, depending on rice intended use: for sale, for 1 year storage and for 5 years storage. The estimated drying conditions for rice are presented in Table1. Specific enthalpy rise, in the preparation of air for the role of drying medium is graphically calculated. Correct enthalpy values are important, because the total heat content of the air

Determines the energy needed to change the conditions of the air from its current state to the desired state. Enthalpy cannot be directly measured.

Accurate values of enthalpy have been determined in research laboratories by measuring the change of properties during a carefully controlled process and, from these properties; enthalpy values relative to an arbitrary reference state point (0 °C for moist air in psychometrics) are calculated.

The value of enthalpy at the arbitrary reference state point is usually designated as having zero enthalpy. The resultant enthalpy values are published in the form of tables or graphs. The specific enthalpy of moist air can be calculated as the sum of the enthalpy of the dry air component, and the enthalpy of the water vapor component,

$$i i i c t ( r x c t ) = d a + w v = p a + o + p w \quad (1)$$

In psychrometric practice the chart “specific enthalpy-humidity ratio” is used to predict the moist air specific enthalpy [13]. The procedures for calculating energy requirements are very different, but they all depend on local climatic conditions. Therefore, the first step in every method of

estimating energy use is to ensure correct climatic information.

### III. DRYING CONDITIONS FOR TOMATO

Tomato contains more than 85 % water and is therefore highly perishable. Dried tomato, in the form of tomato slices or tomato powder, is stable product which can be stored for extended period of time. In our country, at an average area of 6000 ha, 120000 t tomatoes are produced. Low quantities of tomato to be dried and the lack of energy favor the use of solar energy for drying purposes, in the countries with high solar insolation. The introduction of low cost and locally manufactured solar dryers is the opportunity to enhance the use of small or farm solar dryers. During the past decade research in solar drying of tomato has gained considerable activity in Macedonia. Researchers from the Faculty of mechanical engineering and the Faculty of agricultural sciences and food were involved in those activities. Seven dryers were produced, seven teams of farmers and advisers were nominated and the fieldwork results from seven locations were permanently summarized at annual meetings called "Faculty and farmers" organized by the Faculty of agricultural sciences and food.

Three types of dryers were exploited: (1) Farm dryer with rock-bed heat storage, FD-SA, (2) Farm dryer with water-bed heat storage, FD-WA, and (3) Farm dryer with an auxiliary heating system, FD-AS. The dryers FD-SA and FD-WA were imported in our country and submitted to some reconstructions in the stage of assembly. The dryer FD-AS was designed at the Faculty of mechanical engineering in Skopje as a prototype version and two times improved, [14], [15]. Functional draft of farm solar dryer FD-AS is shown in Figure 2. Tomato slices placed on four trays are dried with natural air convection in the drying room. Working medium is the atmospheric air heated in the solar collector. The heat exchanger is used for additional heating by liquefied petroleum gas.

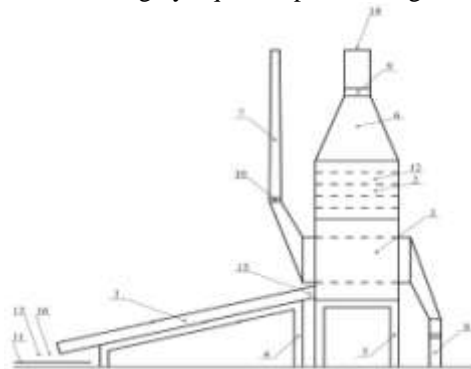

Figure 2: Farm solar tomato dryer FD-SA

Dryer elements: 1 - Solar collector, 2 - Drying room, 3 - Heat exchanger, 4, 5 - Support, 6 - Primary duct, 7 - Secondary duct, 8 - Auxiliary heating source, 9, 10 Elements for regulation, 11- Clean entrance, Measuring points: 12 - Tomato moisture content, 13 - Air inlet conditions, 14 - Air outlet conditions, 15 - Heated air conditions, 16 - Airflow.

Dryer elements were designed in such a way that they can be built with simple techniques, are low in weight for easy transportation and enable easy assembly of the whole dryer. Stainless steel was chosen for the product trays in the dryer room. All the other elements of the dryer were made of galvanized iron sheets.

Applied drying conditions were based on mathematical modeling of the drying process by natural convection, own experience obtained in the fieldwork with solar dryers, and continuous improvement of dryers construction. Air temperature, air relative humidity and air velocity were continuously recorded during the whole drying cycle. The drying process was controlled by measuring the product weight every thirty minutes. Dried tomato at final level of 10 % moisture content wet basis, needed 72 - 106 hours at summer weather conditions for Skopje region. The estimated drying conditions for tomato are presented in Table 2.

Table 2: Drying conditions for tomato

| Parameter                  |                          |         | Dried product: Tomato |
|----------------------------|--------------------------|---------|-----------------------|
| Medium                     |                          |         |                       |
| Air state (In atmosphere)  |                          |         |                       |
| Dry bulb temperature       | $t_a$                    | °C      | 20 - 40               |
| Wet bulb temperature       | $t_{wa}$                 | °C      | 15 - 22               |
| Relative humidity          | $\phi_a$                 | %       | 19 - 58               |
| Air state (In drying room) |                          |         |                       |
| Dry bulb temperature       | $t_r$                    | °C      | 40 - 50               |
| Wet bulb temperature       | $t_{wr}$                 | °C      | 21 - 24               |
| Relative humidity          | $\phi_r$                 | %       | 11 - 18               |
| Airflow                    | $m$                      | $m^3/s$ | 0.3 - 0.6             |
| Specific enthalpy rise     | $\Delta h$               | kJ/kg   | 22 - 31               |
| Humidity ratio rise        | $\Delta W$               | kg/kg   | 0,004 - 0,0097        |
| Product                    |                          |         |                       |
| Initial moisture content   | $X_{w0}^*$               | %       | 85 - 95               |
| Final moisture content     | $X_{wf}^*$               | %       | 8 - 10                |
| Initial temperature        | $t_i^*$                  | °C      | 20 - 30               |
| Final temperature          | $t_f^*$                  | °C      | 35 - 45               |
| Thickness                  | $h$                      | mm      | 3 - 5                 |
| Dryer                      | Farm solar dryer FD - AS |         |                       |

### IV. CONCLUSION

The correct drying conditions for rice and tomato are reached in five steps procedure:

1. Taking into account the normal air temperature amplitude at the dryer location, the state in the atmosphere was predicted with the use of the climatic curve.
2. Enthalpy rise of the outdoor air, in accordance with the allowed drying temperature of the product, was estimated.
3. A specified portion of moist air in the drying room was provided.
4. Correct thickness of the dried product was determined,
5. Dryer construction was continuously improved, during fieldwork period of minimum three consecutive seasons.

Drying conditions are published:

- (1) For local rice sort dried in industrial type dryer, and
- (2) For local tomato sort dried in a farm solar dryer.

#### **REFERENCES**

- [1] Mujumdar A. S. (Editor), Handbook of industrial drying, Marcel Dekker, New York, USA, 1995.
- [2] ASHRAE Handbook HVAC Applications, Chapter 25: Drying and Storing Selected Farm Crops, American Society of Heating, Refrigerating and Air-Conditioning Engineers, Atlanta, USA, 2011.
- [3] Olivieri J., Singh T., Lovodocky S., Psychrometrics Theory and practice, American Society of Heating, Refrigerating and Air-Conditioning Engineers, Atlanta, USA, 1996.
- [4] Gatley D. P., Understanding Psychrometrics, American Society of Heating, Refrigerating and Air-Conditioning Engineers, Atlanta, USA, 2005.
- [5] ASHRAE Handbook Fundamentals, Chapter 1: Psychrometrics, American Society of Heating, Refrigerating and Air-Conditioning Engineers, Atlanta, USA, 2013.
- [6] Mojsovski F., Analysis of humidity level in psychrometric thermal processes, PhD Thesis, Faculty of Mechanical Engineering, Skopje, Macedonia, 2007, (in Macedonian).
- [7] Mojsovski A., Nikolić D., Equilibrium moisture content model of rice, Proceedings of the IASTED International Symposium Modelling, Identification and Control, Grindelwald, Switzerland, 1985.